

Datasheet of SAW Duplexer 1814 Band66(4) Unbalanced

KYOCERA Part No. : SD18 1745R8UUB1

KYOCERA Corporation
All rights reserved

Rating

Items	Rating	Unit	Note
Operating Temperature Range	-20 to +85	deg.C	
Storage Temperature Range	-40 to +85	deg.C	
Max Input Power (Tx port)	+30.5	dBm	5,000hours, Ta=50deg.C, CW
Tx Port Nominal Impedance	50+3.9nH//0.4pF	ohm	Unbalance
Ant. Port Nominal Impedance	50//3.6nH	ohm	Unbalance
Rx Port Nominal Impedance	50+1.5nH	ohm	Unbalance

Dimensions

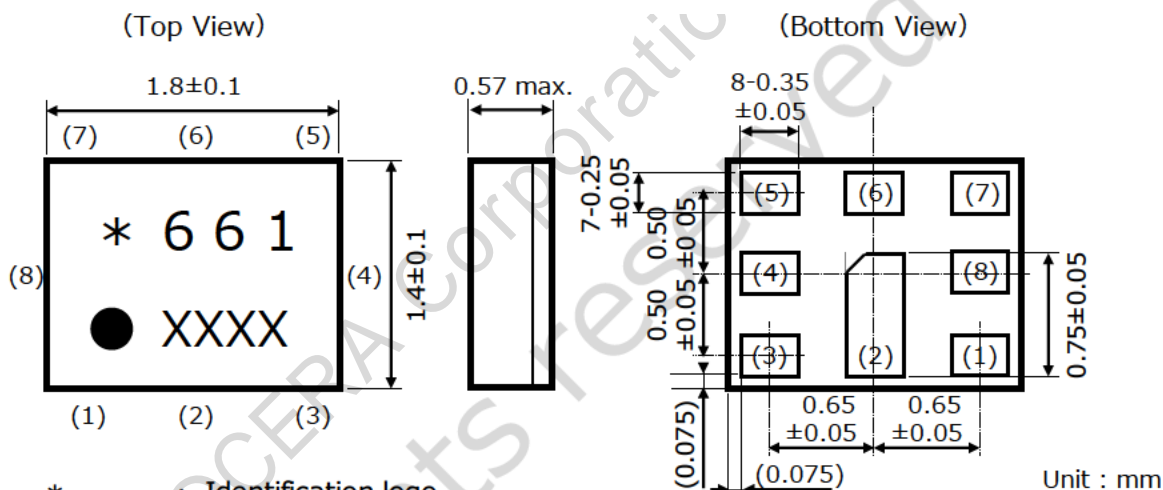

- * : Identification logo
- 661 : Identification no.
- : Index mark of pin 1
- XXXX : Production code

Pin No.	Function
(1)	Rx
(3)	Tx
(6)	Ant.
Others	GND

Recommendable Land Pattern

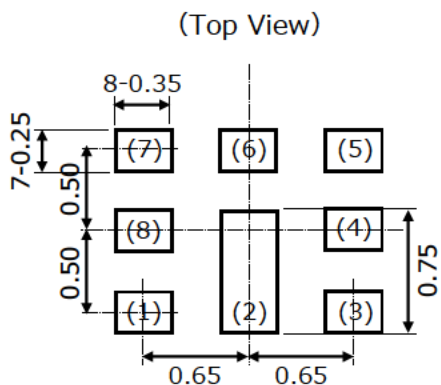

Measurement Circuit

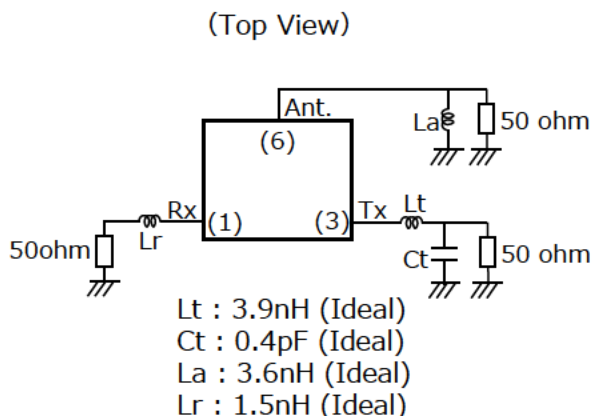

Electrical Characteristics

Items		Frequency Range (MHz)	Characteristics			Unit	Note	
			Min.	Typ.	Max.			
Tx to Ant	Insertion Loss	1710 - 1780	-	1.7	2.8	dB		
	Ripple@20MHz	1710 - 1780	-	0.9	1.9	dB		
	VSWR	Tx	1710 - 1780	-	1.5	2.0	-	
		Ant	1710 - 1780	-	1.6	2.0	-	
	Attenuation	10 - 699	25	53	-	dB		
		699 - 960	30	47	-	dB		
		1559 - 1606	40	49	-	dB		
		2110 - 2200	40	52	-	dB		
		2400 - 2500	35	44	-	dB		
		2300 - 2690	20	42	-	dB		
3300 - 4200		15	19	-	dB			
4900 - 5950	25	28	-	dB				
Ant to Rx	Insertion Loss	2110 - 2200	-	1.8	2.9	dB		
	Ripple@20MHz	2110 - 2200	-	0.5	1.7	dB		
	VSWR	Rx	2110 - 2200	-	1.6	2.0	-	
		Ant	2110 - 2200	-	1.7	2.1	-	
	Attenuation	10 - 699	40	54	-	dB		
		699 - 849	40	51	-	dB		
		1710 - 1780	45	52	-	dB		
		1850 - 1915	39	44	-	dB		
		2305 - 2315	30	39	-	dB		
		2400 - 2500	30	34	-	dB		
2300 - 2690		30	34	-	dB			
4900 - 5950		10	16	-	dB			
Tx to Rx	Isolation	1710 - 1780	55	63	-	dB	Tx	
		2110 - 2200	50	55	-	dB	Rx	

Electrical Characteristics

[Tx to Ant]

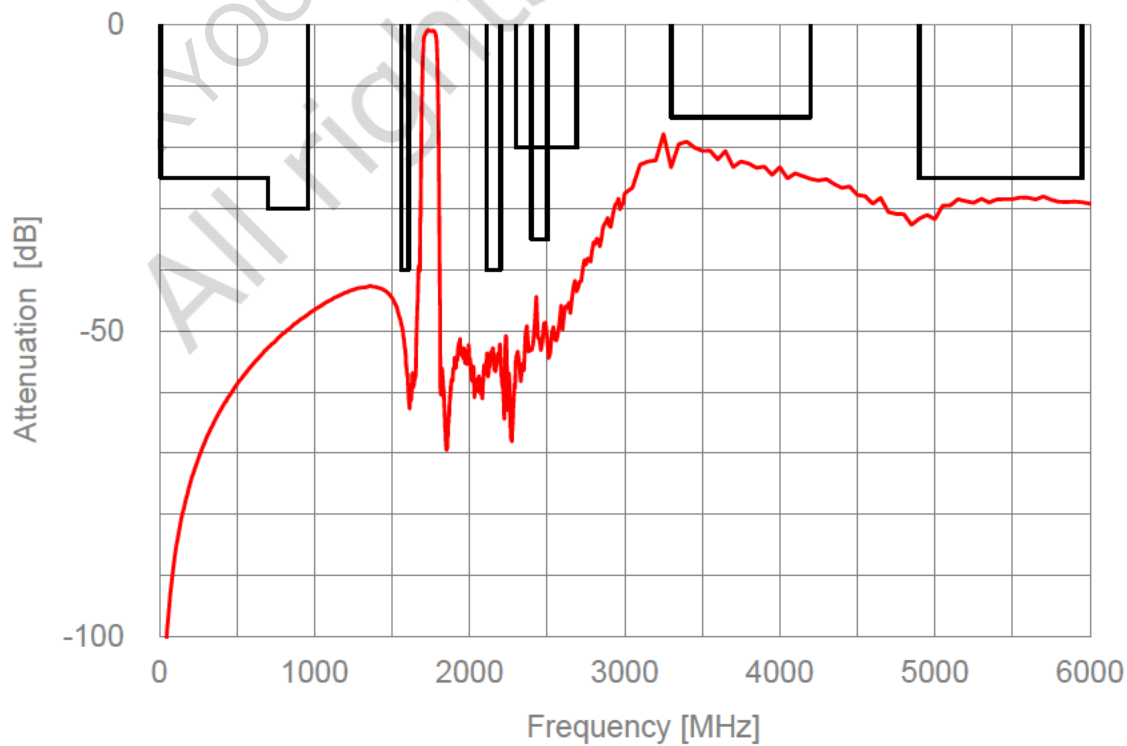
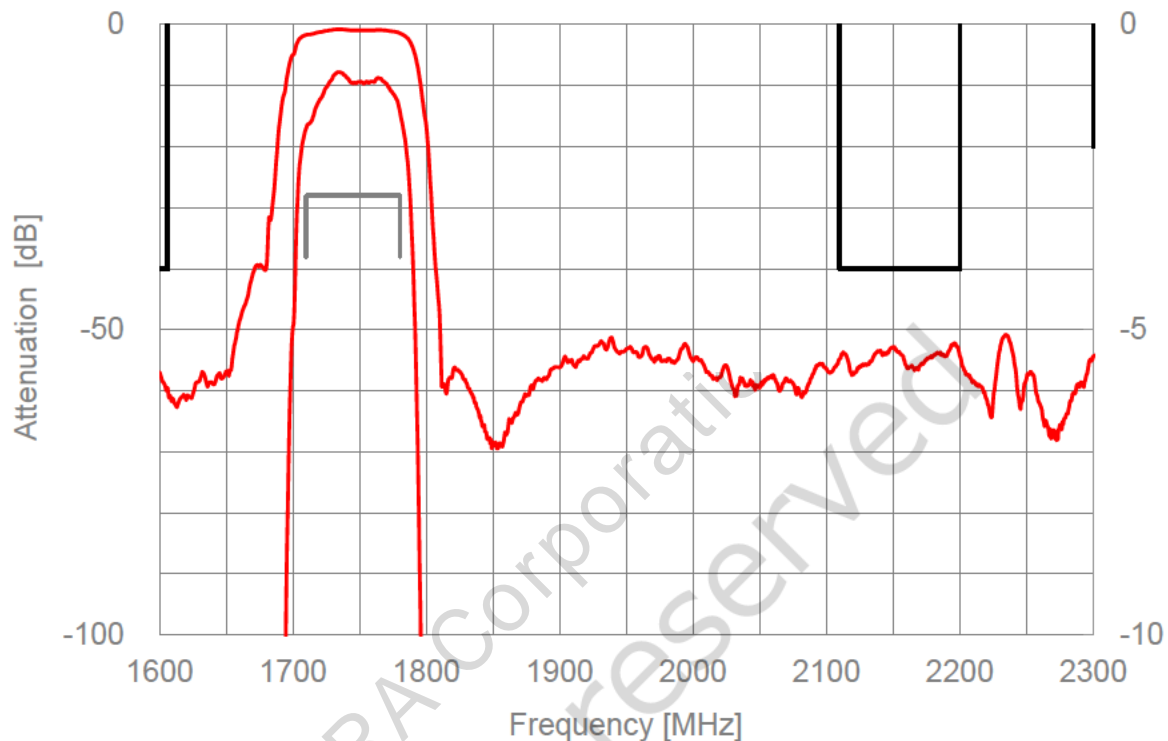

Electrical Characteristics

[Ant to Rx]

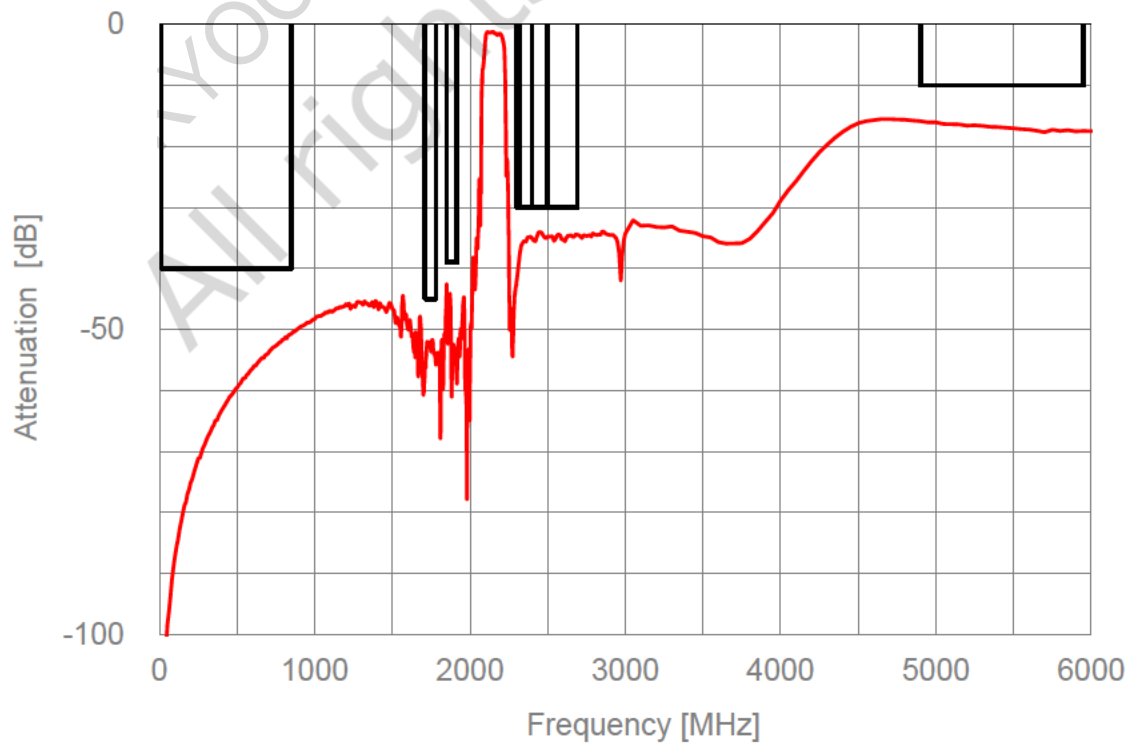
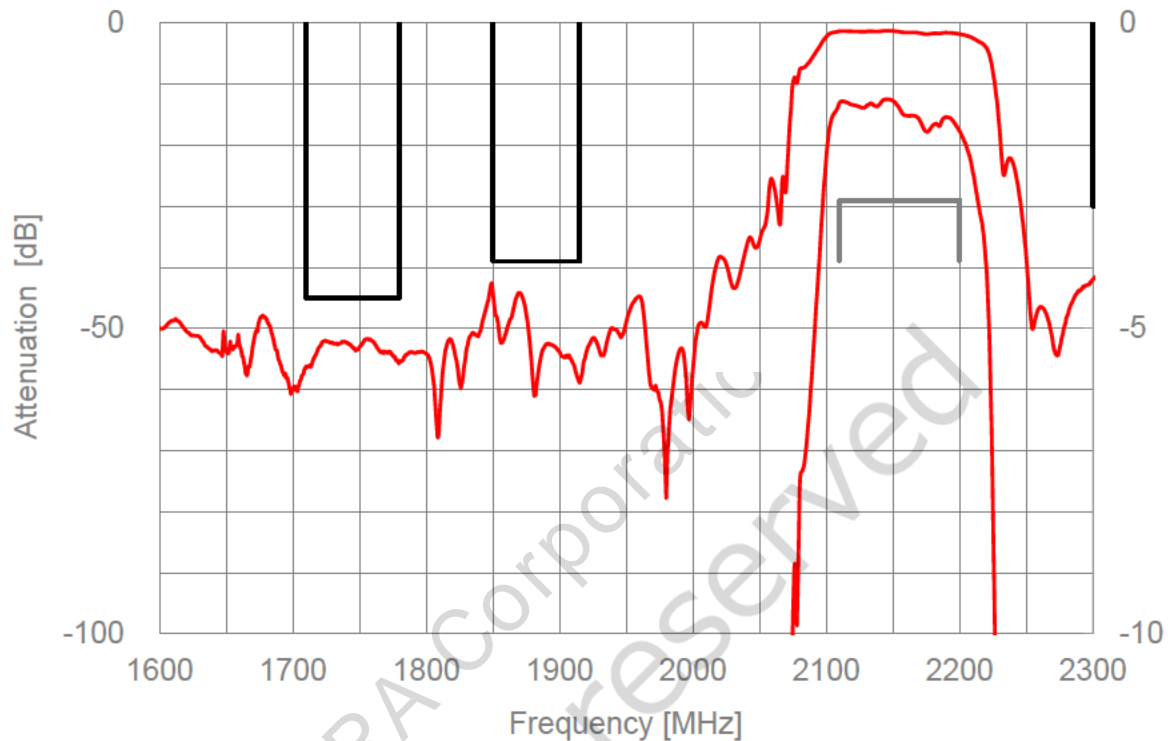

Electrical Characteristics

[Tx to Rx]

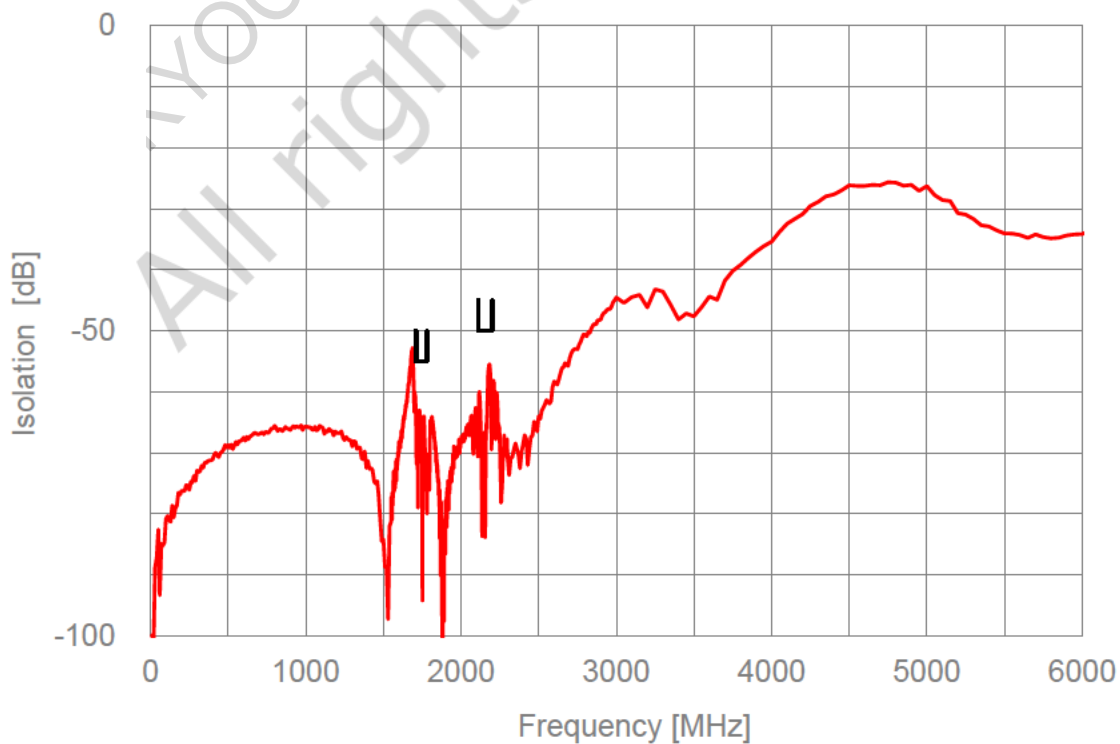
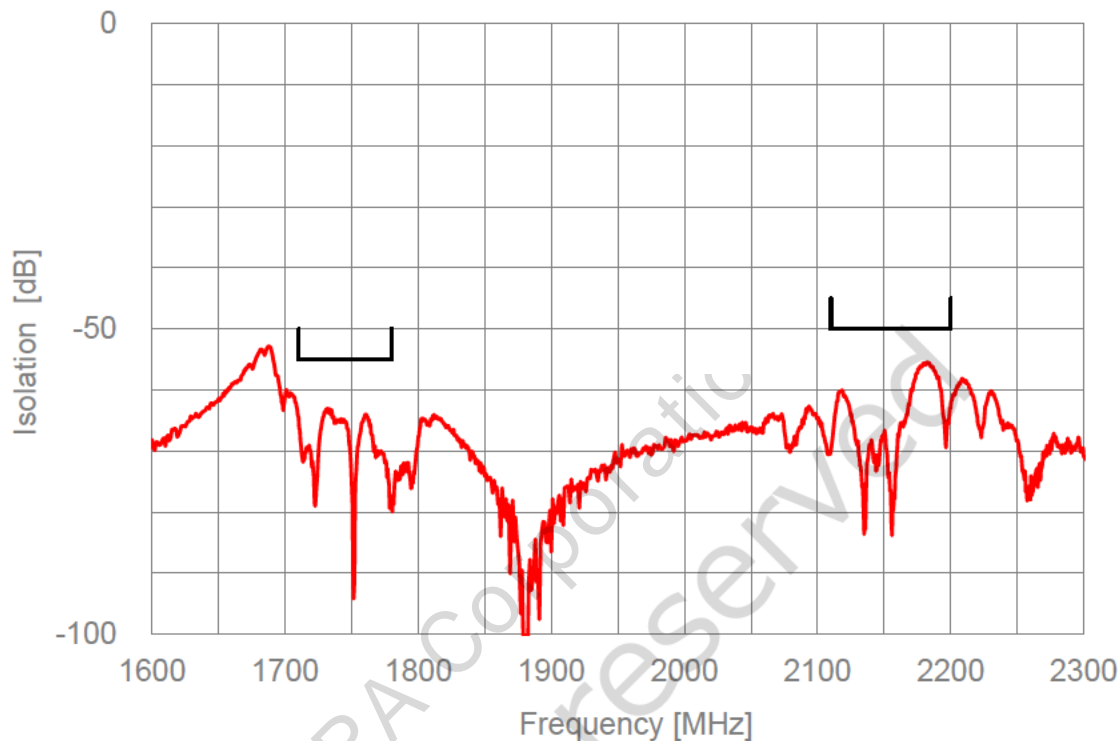

Electrical Characteristics

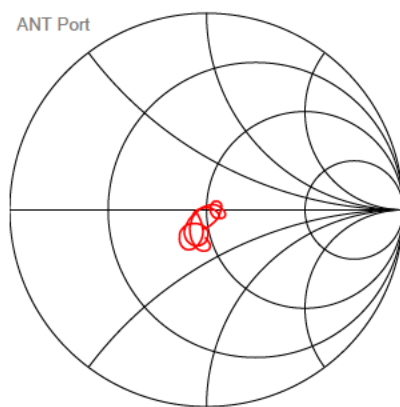
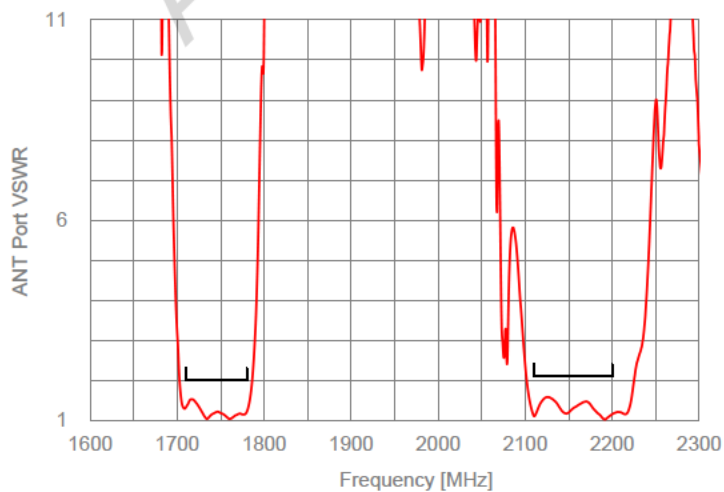
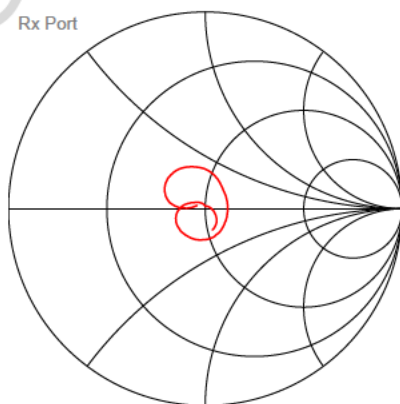
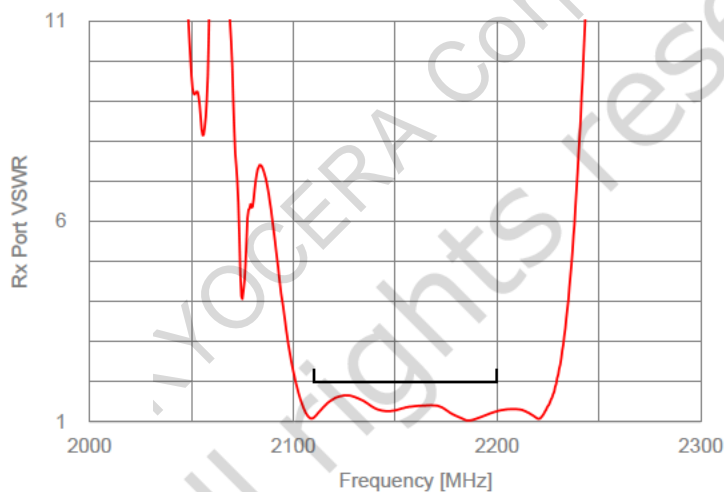
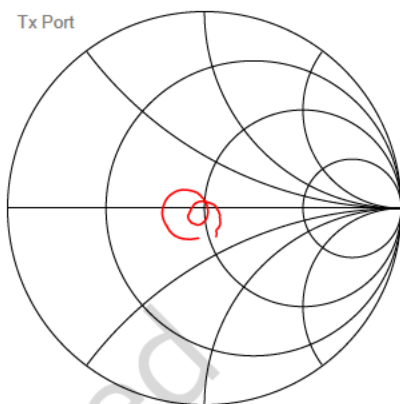
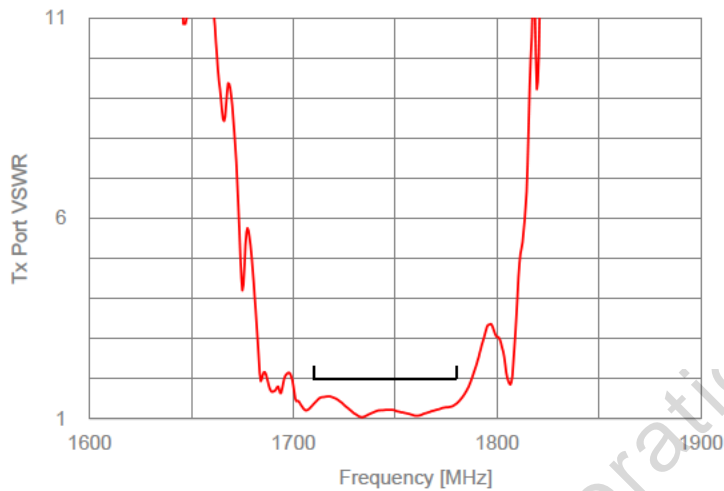

Tape & Reel Specification

[Tape]

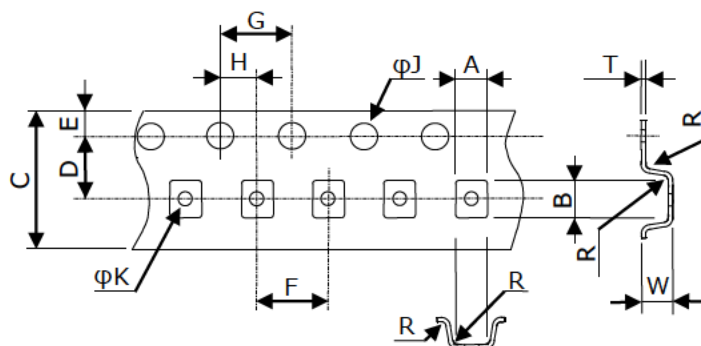

Unit : mm

Part	Dimension
A	1.7±0.1
B	2.05±0.10
C	8.0±0.2
D	3.50±0.05
E	1.75±0.10
F	4.0±0.1
G	4.0±0.1
H	2.00±0.05
φJ	1.5+0.1/-0
φK	0.80±0.05
R	0.2 Max
W	0.7±0.1
T	0.20±0.05

W : Dimension is depth of pockets.

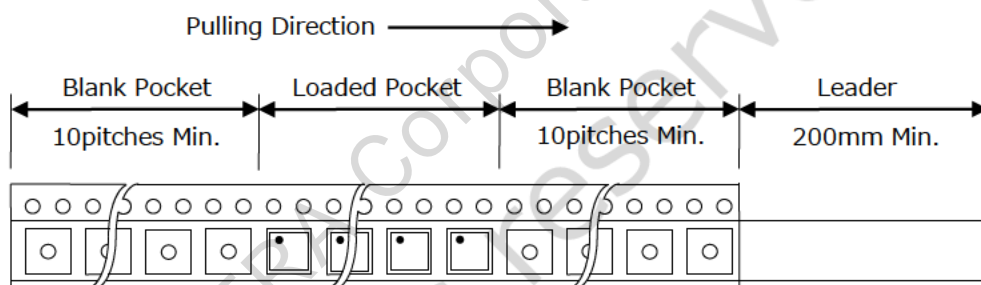

[Reel]

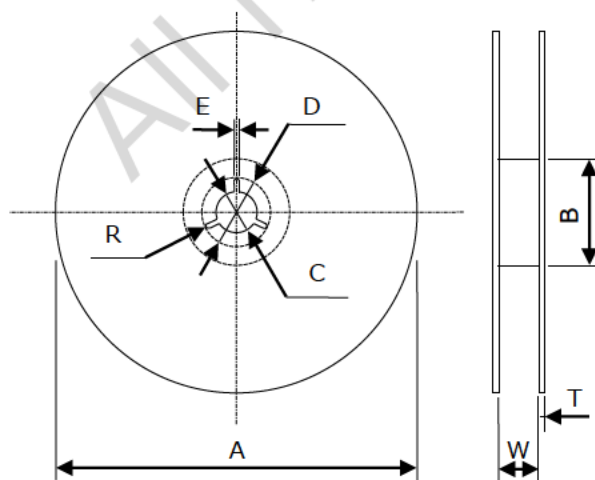

Unit : mm

Part	Dimension
A	178 ± 2
B	60 ± 2
C	13.0 ± 0.2
D	21.0 ± 0.8
E	2.0 ± 0.5
R	1
W	9.5 ± 1.0
T	2.0 ± 0.2

Notice

1. Characteristics described in this datasheet are for references specifications shall be based on written documents agreed by each party.
2. Contents in this datasheet are subject to change without notice. It is recommended to confirm the latest information at the time of usage. Also, this datasheet is revised once a year. We may not be able to accept requests based on old datasheets.
3. Products in this datasheet are intended to be used in general electronic equipment such as office equipment, audio and visual equipment, communication equipment, measurement instrument and home appliances. It is absolutely recommended to consult with our sales representatives in advance upon planning to use our products in applications which require extremely high quality and reliability such as aircraft and aerospace equipment, traffic systems, safety systems, power plant and medical equipment including life maintenance systems.
4. Even though we strive for improvements of quality and reliability of products, it is requested to design with enough safety margin in equipment or systems in order not to threaten human lives directly or damage human bodies or properties by an accidental result of products.
5. It is requested to design based on guaranteed specifications for such as maximum ratings, operating voltage and operating temperature. It is not the scope of our guarantee for unsatisfactory results due to misuse or inadequate usage of products in the datasheet.
6. Operation summaries and circuit examples in this datasheet are intended to explain typical operation and usage of the product. It is recommended to perform circuit and assembly design considering surrounding conditions upon using products in this datasheet.
7. Technical information described in this datasheet is meant to explain typical operations and applications of products, and it is not intended to guarantee or license intellectual properties or other industrial rights of the third party or Kyocera.
8. Trademarks, logos and brand names used in this datasheet are owned by Kyocera or the corresponding third party.
9. Certain products in this datasheet are subject to the Foreign Exchange and Foreign Trade Control Act of Japan, and require the license from Japanese Government upon exporting the restricted products and technical information under the law. Besides, it is requested not to use products and technical information in the datasheet for the development and/or manufacture of weapons of mass destruction or other conventional weapons, nor to provide them to any third party with the possibility of having such purposes.
10. It is prohibited to reprint and reproduce a part or whole of this datasheet without permission.